

DynaRound RG™ System Installation Instructions

Fibergate's ballasted rooftop guardrail system, DynaRound RG™, is designed for safety and fall protection on rooftop applications. Each system is made of durable, weather-resistant fiberglass reinforced plastic (FRP) composite uprights and non-FRP counterbalance weights and connector components. This system meets applicable safety standards in the U.S. and Canada to protect people working at heights.

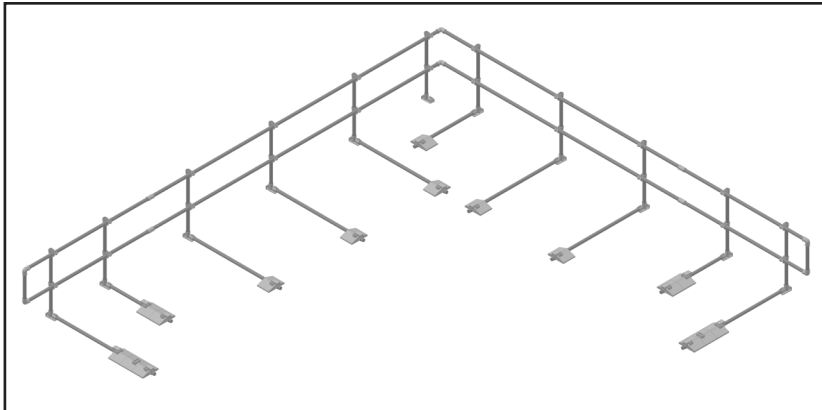

TOOLS REQUIRED

- Circular Saw with carbide or masonry blade for cutting rail tubes to length**
- 25' Tape measure and marking tools or scribe**
- Torque wrench of up to 20 lb-ft or 240 lb-in capacity with 5/16" Allen Key Socket**
- Removable thread locking compound (such as Blue Loctite)**
- The installer is responsible for job site safety and lifting equipment required**

NOTE: Cuts and drilled holes must be sealed to maintain corrosion protection.

IMPORTANT

Read these instructions completely before attempting to install the DynaRound RG™ System. It is important to understand the installation procedure thoroughly prior to beginning work. It is the installer's responsibility to carefully follow fabrication and installation plans and instructions to ensure design performance characteristics of the DynaRound RG™ System. The installer could be liable for claims that result from improper installation.

ASSEMBLY INSTRUCTIONS

1. Inspect and inventory all DynaRound RG™ components and compare to the packing list or bill of materials to verify that all materials are available for installation. Contact Fibergate at 1-800-427-4043 to report any missing material.
2. Inspect the roof to verify that the area where the DynaRound RG™ is to be installed is prepared for installation. Remove any debris/obstructions in the installation area and verify all field dimensions prior to assembling the DynaRound RG™ System.
3. Verify that the locations where the post assemblies will be placed are free of debris and that the roof surface has been protected as directed by the roofing manufacturer.
4. Locate the first post/outrigger and assemble the post and outrigger to the slipper by torqueing the set screws to 15 lb-ft (20.3 N-m). Add a removable thread locking compound (such as Blue Loctite) to the set screws to prevent loosening. Refer to the drawing on page 4 for details of the five types of post/outrigger assemblies. Install the Roofs and Special Hooks on the outrigger and torque the set screws. Verify that the post is plumb using a spirit level. Install the Open Cross Over fittings to the posts in the positions indicated.

Installation Instructions

5. When placing the post/outrigger assemblies, ensure that the bottom surface of the Slipper and the Roofs make full contact with the supporting surface. The heel of the Slipper in each post/outrigger assembly should bear against the roof parapet. If a parapet is absent, the heel of the Slipper must be a minimum of 10'-0" from the roof edge.
6. Locate the next post/outrigger assembly and repeat steps 4 & 5 until all post/outrigger assemblies are in place.
7. Install 20 ft sections of 1.9" OD FRP tube top and mid-rails through the Open Cross Over fittings on the posts. Torque the set screws to 7.5 lb-ft (10.1 N-m). Add thread locking compound to the set screws to prevent loosening. Splice the rails together using PN 504701 Rail Splice Assembly which consists of two PN 793149 Sleeve Joints.
8. At Returns (unsupported terminations of the guardrail), connect the two ends of the 1.9" OD FRP tube using PN 5045010 Return Assembly which consists of a length of 1.9" OD FRP tube and two PN 793125 Two Way Elbows. Torque set screws to 7.5 lb-ft (10.1 N-m). Add thread locking compound to the set screws to prevent loosening.
9. Returns are supported with an A Post Assembly at a maximum of 1'-9" from the unsupported end of the rail and a B Post Assembly at a maximum of 3'-3" from the A Post Assembly. Refer to the drawing on page 3.
10. At 90° corners, connect the 1.9" OD FRP rails using PN 504801 - 90 Degree Splice Assembly which consists of two PN 793125 Two Way Elbows. Torque the set screws to 7.5 lb-ft (10.1 N-m). Add a removable thread locking compound (such as Blue Loctite) to the set screws to prevent loosening. Install one Post Assembly D a maximum of 2'-0" from the corner on one side, and a Post Assembly E at a maximum of 8" from the corner at the other. The next Post Assembly C is at a maximum of 5'-0" from corner as shown. Refer to the drawing on page 3.
11. Maximum spacing of C Post Assembly is 5'-0" on center. Refer to the drawing on page 3.
12. At supported rail terminations to walls, the rails are attached to the wall using PN 504601 Wall Assembly which consists of two PN 793131 Base Flanges. The maximum distance from the last post/outrigger assembly to the wall is 5'-0". The Base Flanges are connected to the 1.9" OD FRP rails via set screws and the Base flanges are connected to the wall or fixed structure using 4 each ¼" diameter countersunk head fasteners. Verify that the wall or other fixed structure can sustain the required loads. Unless noted otherwise, the ¼" dia countersunk head fasteners are to be supplied by the customer and suitable for installation based on the field conditions.
13. After completion, perform a complete inspection of the DynaRound RG™ installation to ensure that the posts are spaced at the correct intervals and that all set screws are torqued to the minimum required torque. The system can then be inspected by the owner or the owner's engineer and accepted. A written log of the final inspection should be kept by the owner.
14. The installed system should be inspected annually by a qualified inspector or Fibergrate representative. This inspection should include checking the sets screws for correct torque, checking for corrosion of the fittings, and inspecting the 1.9" OD FRP tubes for any signs of damage. Any corrective actions required by this inspector must be immediately implemented or the DynaRound RG™ should be clearly tagged as unsafe for use until repairs are implemented. Written logs should be kept of every inspection and any corrective actions documented.

DynaRound RG™ Example Layout

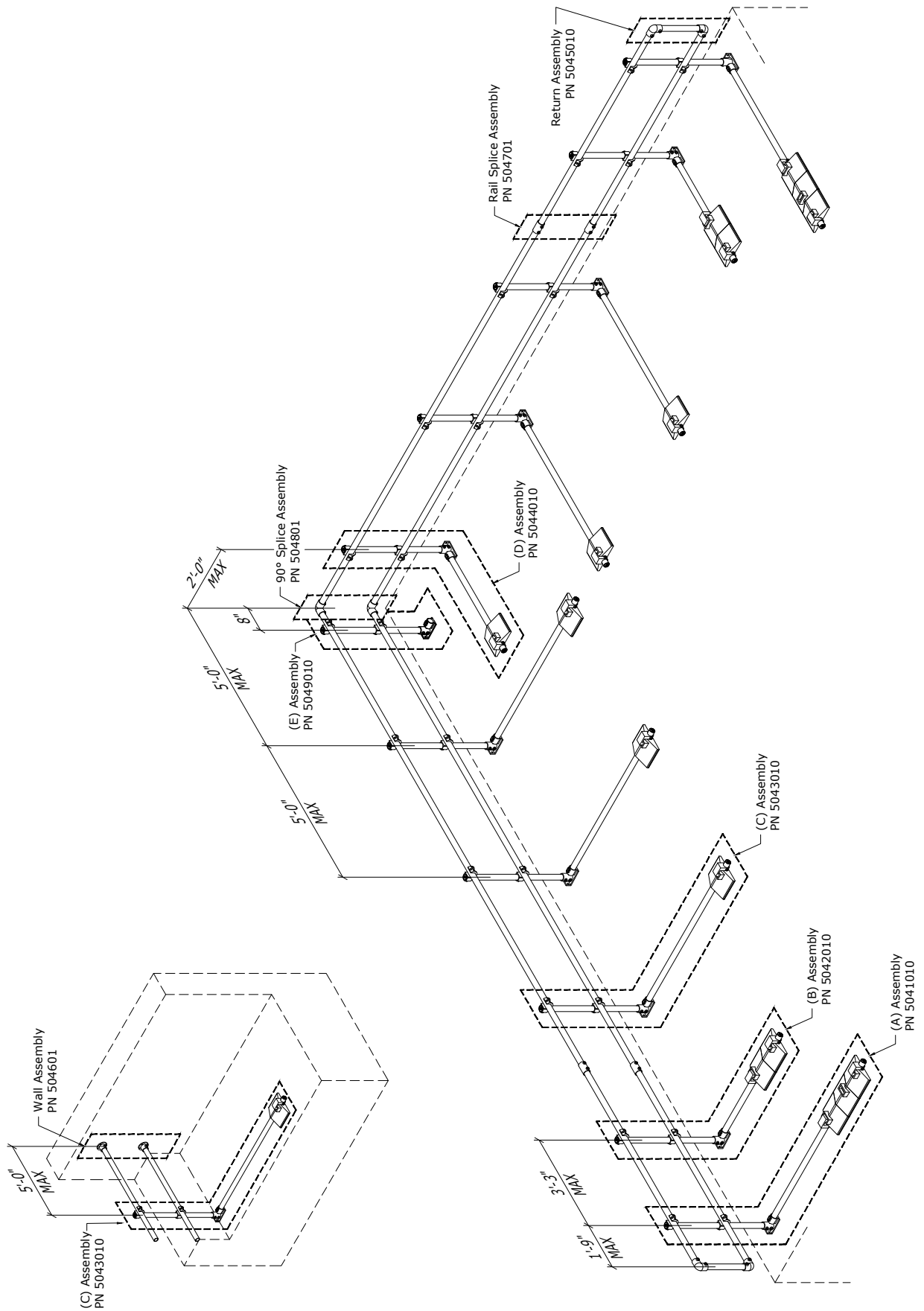

DynaRound RG: Post Assemblies

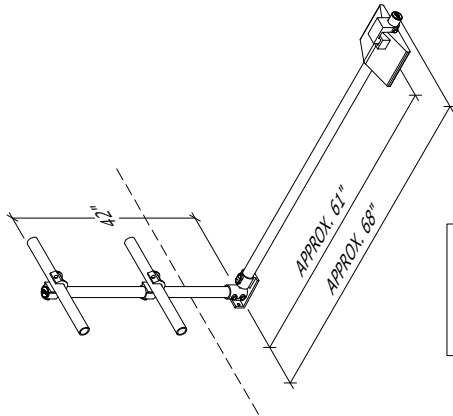

(C) Assembly
PN 5043010

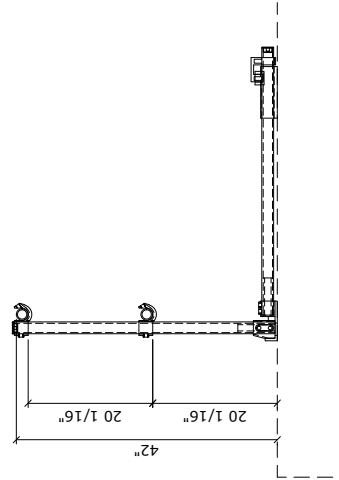

Open Cross Over Location

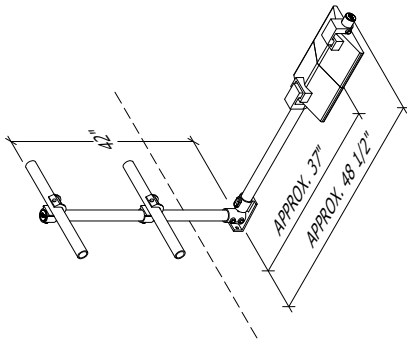

(B) Assembly
PN 5042010

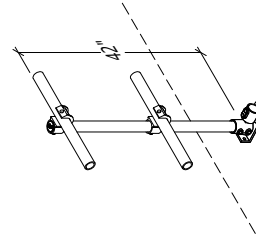

(E) Assembly
PN 5049010

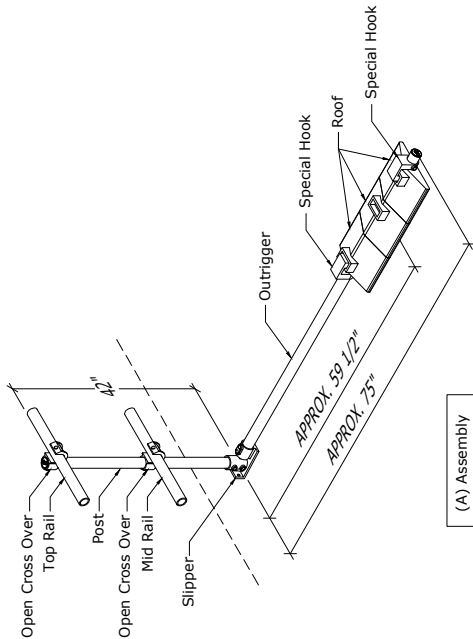

(A) Assembly
PN 5041010

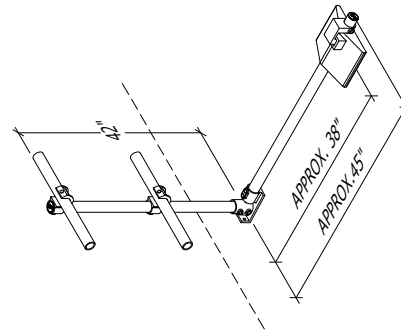

(D) Assembly
PN 5044010



Phone: 972-250-1633
Fax: 972-250-1530



www.fibergrate.com



info@fibergrate.com

Fibergrate Composite Structures Inc. believes the information contained here to be true and accurate. Fibergrate makes no warranty, expressed or implied based on this literature and assumes no responsibility for consequential or incidental damages in the use of these products and systems described, including any warranty of merchantability or fitness. Information contained here is for evaluation only.
©Fibergrate Inc. 2015 - Part No. 883306-12/17 - DynaRound-RG-Assembly-Instructions.pdf

